



Symphony Plus SD Series PROFIBUS Interface: PDP800

Symphony Plus

SD Series PROFIBUS Interface: PDP800

Symphony® Plus is the new generation of ABB's widely acclaimed Symphony family of distributed control systems – the world's most widely used DCS in the power generation and water industries. In all, there are more than 6,500 Symphony DCS installations in operation all over the world, more than 4,500 of which are in power and water applications.

1 SD Series PDP800: Redundant configuration



No other automation platform has such a long field record and large installed base in power and water applications as Symphony. For more than 30 years, ABB has evolved the Symphony family, ensuring that each new generation enhances its predecessors and is backwardly compatible with them – all in accordance with ABB's long-held policy of 'Evolution without obsolescence.'

Included in Symphony Plus is a comprehensive suite of standards-based control hardware and software that meets the requirements of total plant automation. The SD Series PROFIBUS interface, PDP800, provides connection between the Symphony Plus controllers and PROFIBUS DP communication channels. This allows for easy integration of intelligent devices such as smart transmitters, actuators and intelligent electronic devices (IEDs). Each device's resident information can then be used in control strategies and higher level applications.

In addition to producing tighter and more reliable process control solutions, PDP800 PROFIBUS solutions lower installation costs by reducing wiring and system footprint. System costs are further reduced by using S+ Engineering to configure and maintain PROFIBUS networks and devices and their related control strategies.

Seamless intelligent field device integration

Symphony Plus controllers seamlessly integrate field devices through its PDP800 PROFIBUS interface module. This allows access to a wide range of intelligent field devices including transmitters, actuators, motor control centers (MCC), flame scanners, intelligent electronic devices, etc, from ABB and other third-party vendors. PROFIBUS I/O and related control strategies are configured using ABB's extensive set of field-proven standard function code algorithms and S+ Engineering's graphical design tools. Furthermore, this data is provided to other S+ system nodes (ie, control, operation, engineering and information) over the redundant Plant Network (PN800).

PDP800 PROFIBUS interface features include:

- Supports PROFIBUS DP V0, V1, V2
- Supports PROFIBUS PA devices through DP/PA linking device
- Supports 1 msec time stamping of devices by PROFIBUS DP V2
- Supports electric and fiber optic media for PROFIBUS DP link
- Up to 12 Mbps rate of PROFIBUS DP link
- Up to 15 km by fiber optic PROFIBUS DP link

Comprehensive I/O support

The PDP800 module enables the connection of Symphony Plus controllers to S800 I/O via PROFIBUS DP V2. S800 I/O provides options for all signal types, ranging from basic analog and digital inputs and outputs to pulse counters and intrinsically safe applications. S800 I/O sequence of events functionality is supported by PROFIBUS DP V2 with 1 msec accuracy event time stamping occurring at the source.

Additionally, the PDP800 supports Symphony Plus controllers' connectivity to S+ Turbine's specialty modules. Specifically, via PROFIBUS DP V2, the HPC800 can support powerful turbine control solutions for turbine protection (TP800), valve positioning (VP800), generator auto synchronization (AS800) and condition monitoring (MCM800).

Using fiber optic extensions, PROFIBUS I/O modules and devices can be placed up to 15 km from the PDP800. Additionally, PDP800 modules can be located up to 3 km from the controller via redundant HN800 fiber optic communications.

High reliability and availability

The PDP800 supports full redundancy at all levels, including the PDP800 module, power supplies, PROFIBUS DP link, and controller communication bus (HN800). All redundancy options are independent from each other to ensure the highest level of availability and reliability.

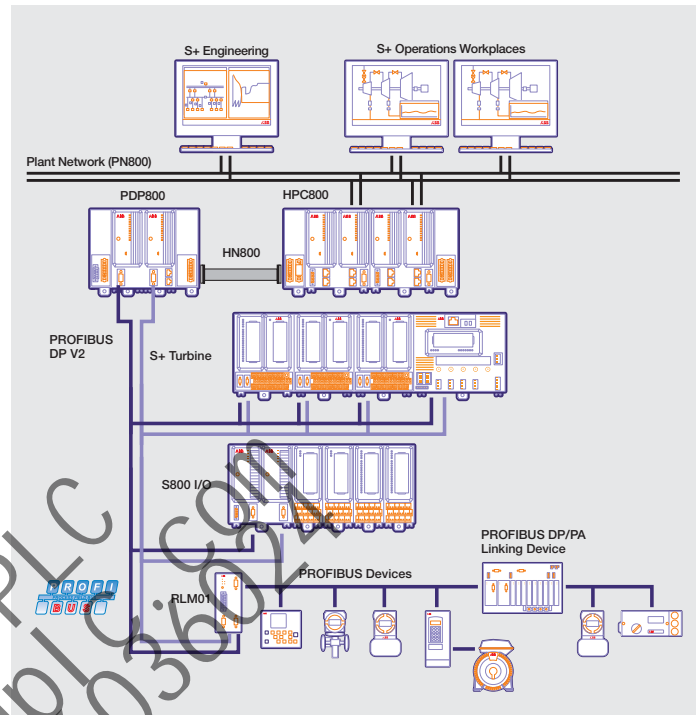

2 PDP800 functional overview

Data accessible by control application

PROFIBUS device cyclic data is accessed by function code control applications in Symphony Plus controllers. Data can be calculated, used as part of a control strategy, or for display and alarming at the S+ Operations console.

A functional overview of the capabilities of PDP800 is shown in figure 2.

Manage intelligent field devices

PROFIBUS devices are fully integrated with the Symphony Plus system, yielding benefits far beyond reduced footprint and cable costs. Within the S+ Engineering workbench, the Field Engineering tool supports configuration, commissioning and maintenance of PROFIBUS devices using device type manager (DTM) technology. For field devices that have conventional device description files (GSD), a basic PROFIBUS DTM is available to allow standardized configuration. The individual device DTMs can be accessed from Composer's multiple data views, such as the system or location overview, and others. It includes automatic net calculation and loading of process items by using the device-specific channel configuration generated from the DTM.

Contact us

ABB S.p.A.

Power Generation

Genova, Italy

Phone: +39 01060731

Email: powergeneration@it.abb.com

ABB Inc.

Power Generation

Wickliffe, Ohio, USA

Phone: +1 440 585 3087

Email: powergeneration@us.abb.com

ABB AG

Power Generation

Mannheim, Germany

Phone: +49 621 381 3000

Email: powergeneration@de.abb.com

ABB Pte. Ltd.

Power Generation

Singapore

Phone: +65 6776 5711

Email: powergeneration@sg.abb.com

www.abb.com/powergeneration



© Copyright 2014 ABB

All rights reserved. Specifications subject to change without notice.

Pictures, schematics, and other graphics contained herein are published for illustration purposes only and do not represent product configurations or functionality.

User documentation accompanying the product is the exclusive source for functionality descriptions.

Symphony is a registered trademark of ABB S.p.A.

HighFive PLC
Sales@5ghplc.com
+86 13306036024